

Cross Talk

Winter/Spring 2012

The **New** **Field Testing** **Backflow** **Preventers** Instructional Video

The all new Field Testing Backflow Preventers, Instructional Video is the perfect training tool for those interested in learning how to field test backflow prevention assemblies. And for the first time, the instructional video demonstrates the field test procedures according to the *Manual of Cross-Connection Control, Tenth Edition*. Plus, with over two and a half hours of live action and computer animation sequences it is the most comprehensive instructional video the USC Foundation has ever released.

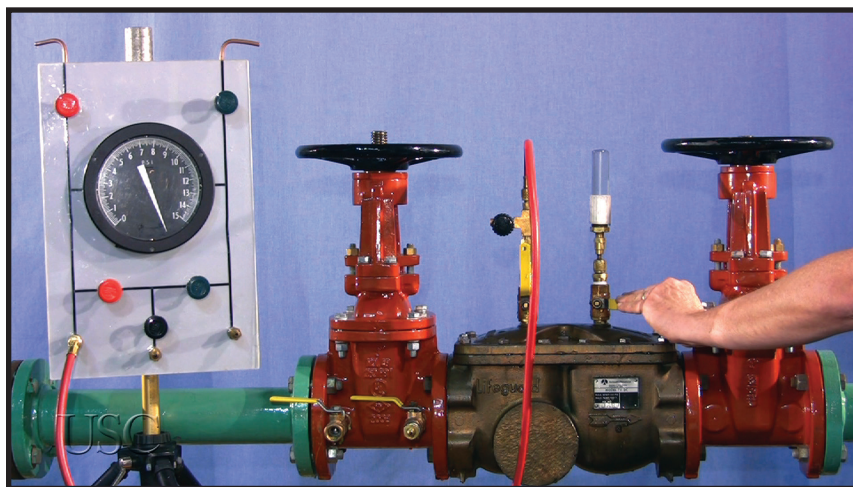

The new instructional video has been produced from the ground-up. The video has been entirely shot in high definition and new computer animation sequences have been created to help testers better understand the inner workings of the assemblies. New narration with alternating male and female voices helps keep the pace lively and fresh.

The new instructional video depicts the field test procedures and troubleshooting scenarios for the reduced pressure principle backflow prevention assembly (RP), double check valve backflow prevention assembly (DC), pressure vacuum breaker assembly (PVB) and for the first time ever the spill-resistant pressure vacuum breaker assembly (SVB).

continued on **page 3**

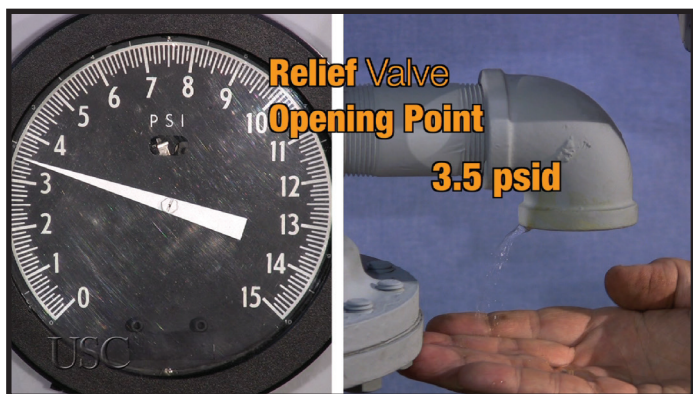

Contents

Hydraulic Lock p. 4

Disc **Compression** p. 5

Exercising the **Relief Valve** p. 6

Testing the **Double Check** p. 8

Location of **No. 4 Test Cock** on **Detector Assemblies** p. 10

Foundation

Membership

The Foundation's Membership Program provides many benefits to the Members of the Foundation. These include: a twenty-five percent discount on manuals, twenty percent discount on Foundation Training Courses for any employee of the Member company/organization, the *List of Approved Backflow Prevention Assemblies* with access to the up-to-the-minute version on the Foundation's website.

Members are encouraged to call the Foundation with technical questions. The Foundation's Engineering Staff is available to assist Members with the various aspects of field testing backflow preventers, installing backflow preventers and administering their cross-connection control program.

Below is a list of those who have become members of the Foundation since the last *Cross Talk*:

101 Water Consulting Group	Clark Patterson Lee	Randy Wright
4Site Engineering, PLLC.	Crazy Mountain Services, LLC.	Rescue Dog Construction
AA Sprinkler & Backflow	Danny Cole DTM	RJ Fire Sprinkler Systems Inc.
AAA Precision Backflow, LLC	Dave's Plumbing	Simply Backflow
Advanced Backflow, LLC	Donald Gallo, Consulting Engineer	Specialty Plumbing, Inc.
Alisal Water Corporation	City of Durham, Dept of Water Management	Telamon Engineering
Ambassador Fire Protection LLC.	G&G Environmental Compliance, Inc.	Texas Star Fire Systems, LLC.
American Way Car Wash	Grossmont-Cuyamaca CC District.	The Backflow School, Inc.
Back Flow Tec	Hansen's Plumbing & Mechanical	Trites Backflow Services
BackflowDirect.com	Hawk Mechanical Contractors, Inc.	Utility Services of Alaska
Bayne Brothers LLC.	James Cochran	
Calculated Fire Protection Co., Inc.	John Banoczi	
California Backflow	Landale Mutual Water Co., Inc.	
Citizens Energy Group	LPSCO dba Liberty Water	
Civiltec Engineering, Inc.	Navin Sahni	

Cross Talk is published by the Foundation for Cross-Connection Control and Hydraulic Research, a division of the University of Southern California, for Foundation Members. 2012 © University of Southern California. All rights reserved.

Note to Members

new ftpb video: continued

continued from **page 1**

In addition, the new instructional video includes the complete field test procedures and troubleshooting scenarios for the RP using a 5, 2 and 3-needle valve field test kit. In the procedures for the DC, PVB and SVB

the 5-needle valve test kit is used, but where an action on a 5-needle field test kit differs on a 2 and 3-needle valve field test kit, an inset depicts the step using a 2 and 3-needle valve field test kit.

Furthermore, the new instructional video includes subtitles in English and

Spanish in order to make the instructional video accessible to a wider audience.

With a new menu structure in place, testers will be able to jump around between different field tests and troubleshooting scenarios at their own pace. For those testers who own a copy of the *Manual of Cross-Connection Control, Tenth Edition*, the new instructional video is an ideal companion.

The video will initially be made available on a two-disc DVD set with a Blu-ray version coming later this year.

The two-disc DVD set may be ordered now by members for \$40. The instructional video may be ordered online on the USC Foundation website or via phone by contacting the USC Foundation office. The Foundation expects the DVDs to be shipping by the time this *Cross Talk* is in the hands of Members. ■

The USC Foundation would like to thank all its members for their patience as it finished up the new *Field Testing Backflow Preventers, Instructional Video* according to the field test procedures found in the *Manual of Cross-Connection Control, Tenth Edition*.

For the past six months the Foundation has not published a new *Cross Talk*. With all of the staff's time and effort focused on completing the Field Testing Backflow Preventers Instructional Video, it was necessary to postpone any new *Cross Talk*'s. Beginning with this issue, *Cross Talk* will be back on schedule for quarterly publication, bringing to you the latest news and information regarding cross-connection control.

In what may have seemed like an eternity for some of you, the USC Foundation has completed production on the new instructional video which is now available for purchase on the Foundation website or via phone.

With all new live action and computer animation sequences the instructional video will help aid backflow prevention assembly testers in field testing and troubleshooting backflow prevention assemblies. More on the key features of the new instructional video may be found in this issue of *Cross Talk*.

We apologize again for the inconvenience and encourage anyone with questions to contact the Foundation office via e-mail (fccchr@usc.edu) or phone (866-545-6340). ■

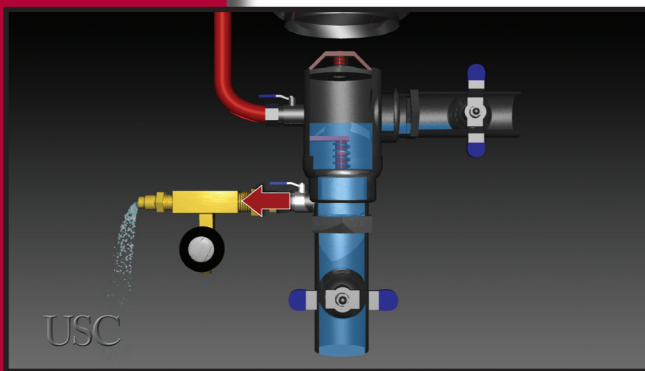
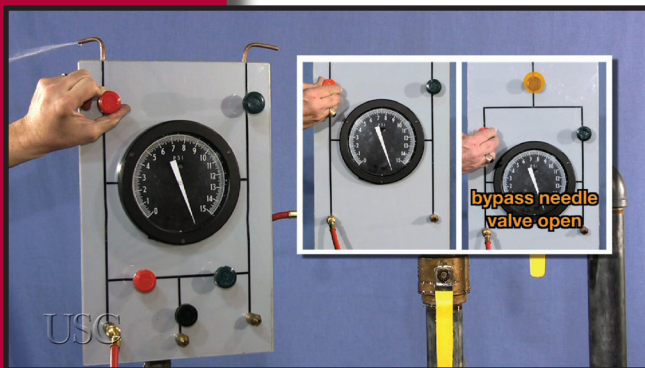

Hydraulic Lock

Once in a while a tester will have an incredibly difficult time removing internal components from a backflow preventer. Once the component is finally removed, the tester may discover no reason why the component wouldn't come out in the first place. The cause in these cases is possibly a phenomenon called hydraulic lock.

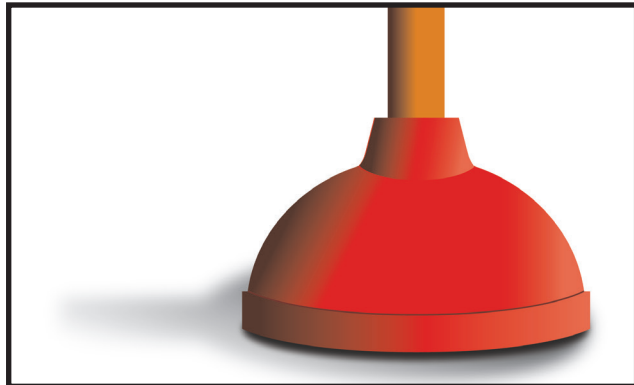

Suction cup is placed on smooth surface

Hydraulic lock works on the same principles as a suction cup. When a suction cup is applied to a surface, especially after being moistened, it sticks. The suction cup can hold steady, even when being pulled with great force. When a suction cup is put in place, all of the air between the suction cup and a smooth surface is evacuated. When the suction cup is removed, the center of the cup lifts off the surface first. As it is pulled away, it creates a vacuum between the cup and the smooth surface. Since the edge of the cup is sealed against the smooth surface, no air can come in to break

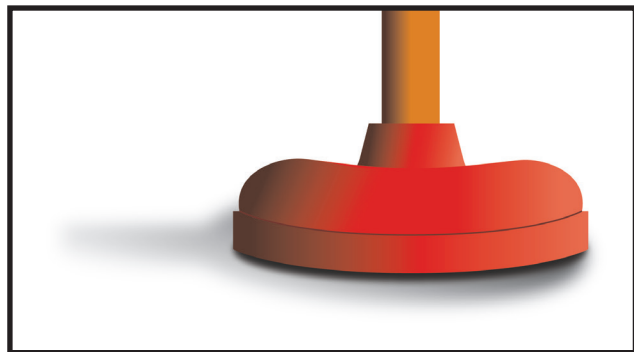

Pressing down on the suction cup creates a vacuum between the cup and the smooth surface by evacuating most the air

the vacuum. Only by great force, or lifting the edge of the cup, can the vacuum be broken and the suction cup lifted.

This exact same phenomenon can occur inside of a backflow prevention assembly. The rubber disc material acts as the suction cup. Depending upon the geometry of the assembly the disc may get "stuck" in position, when pressure is dropped upstream of the check valve. This, in essence, is the same as with a suction cup. The chamber upstream of the check valve acts like the volume under the cup of the suction cup. As one tries to pull the check valve out, it is held in place by the suction upstream of the check.

When disc compression (see Disc Compression on page 5) occurs, the rubber disc material can be pushed into the seat of the check valve. If the region just upstream of the check valve is sealed (like the suction cup), a hydraulic lock can make it very difficult to remove components.

Unlike the suction cup, the backflow

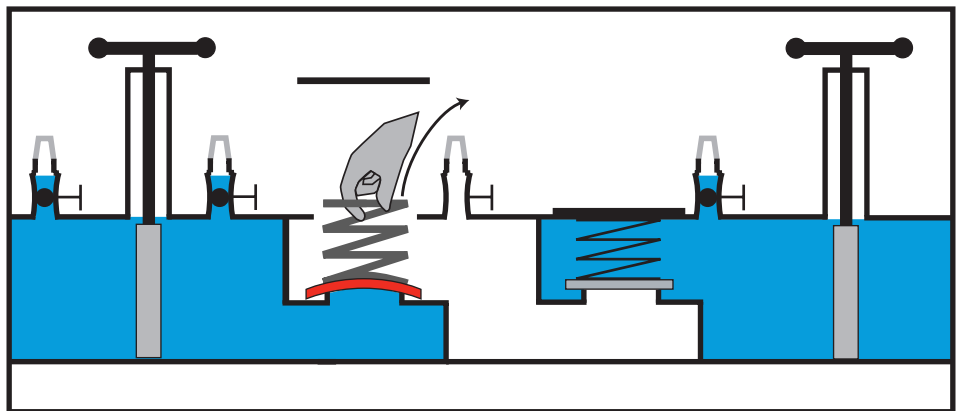

Tester trying to pull components, which are hydraulically locked, out of a backflow prevention assembly

preventers have a built in way to break the hydraulic lock—the test cocks. Simply open the test cock upstream of the check valve. This will allow air into the chamber upstream of the "stuck" check valve and break the vacuum. Always be careful when opening a test cock. Once the test cock has been opened, the hydraulic lock is broken and the

continued on **page 11**

Disc Compression

The term “disc compression” may be occasionally used by a tester, as a reason for varied or false readings on a backflow prevention assembly. And, understanding what disc compression is and how it can affect field test kit readings will help the tester identify and compensate for it.

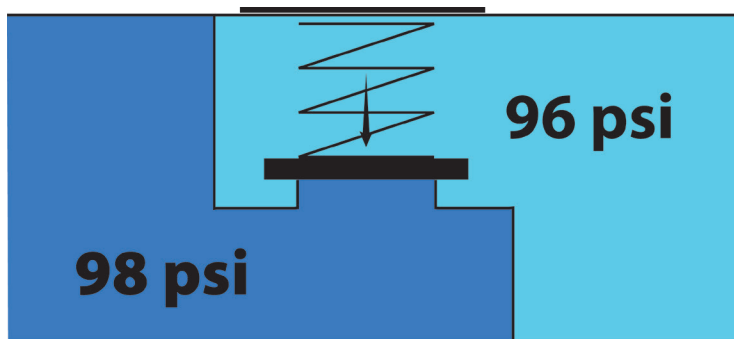

Pressure on the upstream of the check valve is higher than that of the downstream

One point that is important to understand when discussing disc compression is the fact that (at constant temperatures) pressure and volume are inversely proportional in ideal fluids. This means that as the pressure increases the volume decreases. If the pressure decreases, the volume increases. (NOTE: Although water is considered an incompressible fluid, for the purposes of backflow prevention assembly testing it does act as if it is compressible. This is due to tiny pockets or bubbles of air within the various regions of the backflow preventer. The air is actually compressing, giving the water the effects of compressing.)

One of the most common observances of disc compression in the field test procedure is during the second check valve test on the reduced pressure principle assembly. During this test, high pressure is taken from the No. 2 test cock, bypassed through the field test kit and inserted behind the second check valve through the No. 4 test cock. This pressure can force the second check valve disc into the seat of the second check valve. As the seat imbeds into the disc, the portion of the disc in the throat of the seat protrudes into the region between the two check valves. As this

elastomer disc takes up more of the region between the check valves, the water (or air bubbles within the water) compresses, or is reduced in volume. This, in turn, causes the pressure to increase. As the pressure in the region between the two check valves increases, this increases the pressure at the No. 3 test cock.

During the entire test of the reduced pressure principle assembly the high side of the field test kit is attached to the No. 2 test cock and the low side is attached to the No. 3 test cock and the field test kit is reading the difference between the two. When pressure at the No. 3 test cock increases, this brings the pressure at the No. 2 test cock closer to the pressure at the No. 3 test cock. The difference between the two decreases, causing the field test kit reading to drop.

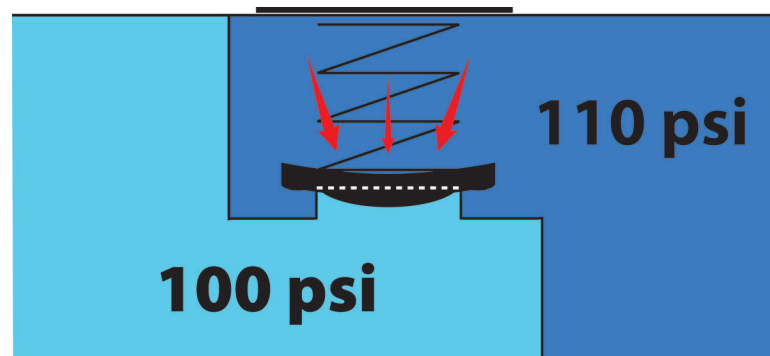

In this example, 110 psi backpressure forces a portion of the disc to protrude into the region upstream of the 2nd check valve increasing the pressure from 98 to 100 psi

Normally the drop in the field test kit reading is not significant, however, it is possible that the reading may drop to the relief valve opening point. This is why it is necessary to bleed the low side of the field test kit again, even if the reading drops to the relief valve opening point. Bleeding the low side of the field test kit releases the pressure added by disc compression and compensates for it. Once the reading settles again, the field test kit reading is indicating the actual static pressure drop across the No. 1 check valve and this is the value recorded. ■

Exercising the Relief Valve

In field testing the reduced pressure principle backflow prevention assembly it is critical that the relief valve opening point be determined before exercising the relief valve. In the preliminary steps of the field test procedure it is possible to accidentally activate the relief valve. When this happens the relief valve is exercised. If the relief valve had been sticking, exercising it may have loosened it up so that the reading recorded at the time of

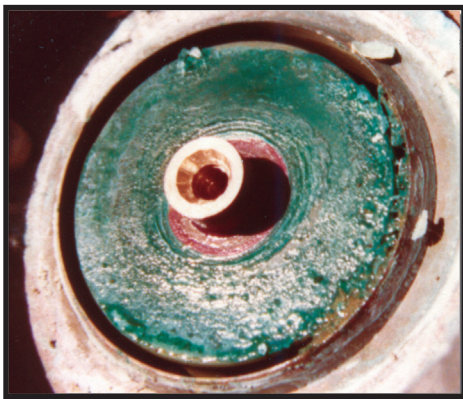

testing the relief valve is quite different than it would have been had the relief valve not been exercised. When backflow occurs, it never exercises the

relief valve first. It just occurs. When it does occur it is important to know how the assembly will react. This is why it is essential that the tester not activate the relief valve before recording the relief valve opening point.

The relief valve is activated when the differential pressure across the first check valve drops to some level. (In a successful field test this differential pressure must be 2.0 psid or greater) This can occur by either decreasing the pressure upstream of the first check valve or increasing the pressure downstream of the first check valve. One way to help ensure that the relief valve is not activated prematurely is to have water flowing through the assembly.

When the pressure drop across the whole assembly increases, this is also an indication that the pressure drop across the first check valve increases. This is an indication of the force being used to open the check valve. At a no-flow condition, the pressure

drop across the assembly is steady. As water starts to flow through the assembly more pressure is lost due to friction loss and the opening of the check valves. Once the check valves are opened a fair amount there is less force required to keep them open. This is why the flow curves of the various backflow preventers tend to have similar characteristics. One thing consistent in all flow curves is the sharp increase in pressure loss as the flow increases from a no-flow condition.

Because of the pressure loss characteristics of backflow preventers, the possibility of activating a relief valve can be reduced substantially if flow is established through the assembly during certain preliminary steps in testing. This is why there is a very specific order in the *Manual of Cross-Connection Control, Tenth Edition*, for bleeding the test cocks on the RP.

Chapter 9.2.1.2, Step a of Test No. 1:

Bleed water through test cocks to eliminate foreign material. Open No. 4 test cock to establish flow through the unit, then open test cocks No. 3, No 2 (open No. 2 test cock slowly), and No. 1. Then close test cocks No. 1, No. 2, No. 3 and No. 4. Be careful not to activate the differential pressure relief valve while bleeding the test cocks.

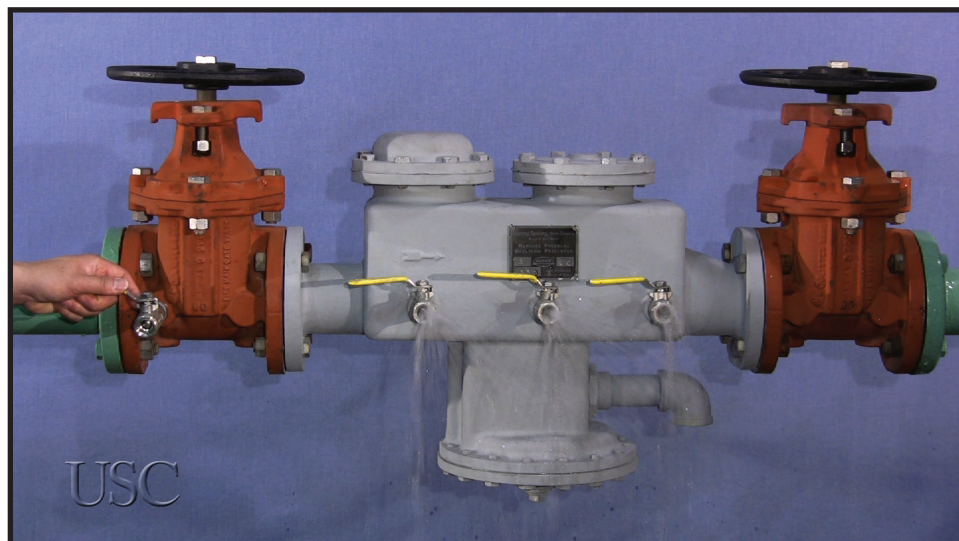

As water flows out of test cocks No. 3 and 4 it is flowing through the No. 1 check valve, thus increasing the pressure loss across the No. 1 check valve. This significantly reduces the possibility of discharging the relief valve. This is especially important while opening the No. 2 test cock. The No. 2 test cock is located on the assembly upstream of the number one check valve. Opening this test cock will reduce the pressure upstream of the No. 1 check valve. If this is done suddenly the differential pressure across the No. 1 check valve can drop, discharging the relief valve.

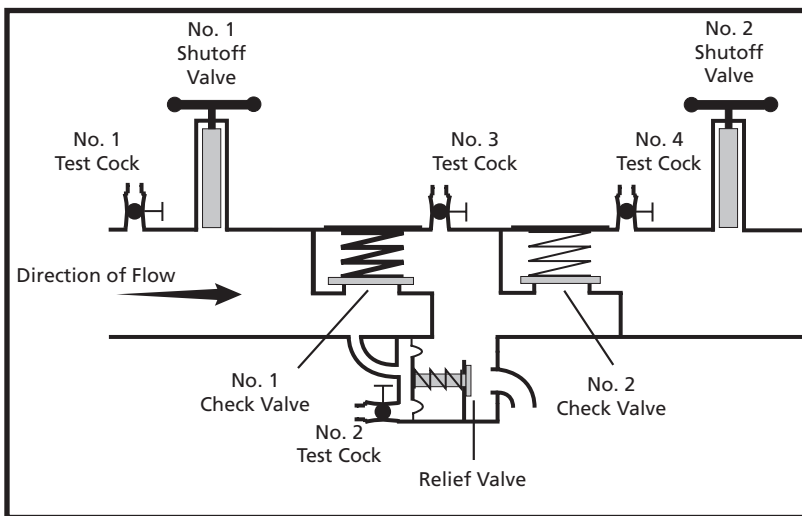

This is especially critical when the No. 2 test cock is located on the high side of the relief valve diaphragm as shown in the illustration above. If, however, water is flowing through the assembly when the No. 2 test cock is opened, the overall differential pressure across the No. 1 check valve is higher and, therefore, the relief valve is less sensitive to pressure changes. This is why it is so important to have water flowing through the No. 3 and No. 4 test cocks when the No. 2 test cock is opened.

The sensitivity of the relief valve explained above may be more prevalent in RP's approved under the 8th Edition of the Foundation's Standard and earlier. Because of the input from Testers in the field, in 1993 the 9th Edition Standard for RP's included a laboratory test where each test cock was slowly opened one at a time to the fully open posi-

tion, and the relief valve could not discharge. This laboratory test continues into the current 10th Edition Standard (10.1.2.2.3.4). This is called the relief valve sensitivity test.

Flushing the test cocks is not the only way the relief valve can be activated accidentally. Bleeding the air from the field test kit can cause the same effect. When the field test kit is attached to the assembly, the high side hose is attached to the No. 2 test cock. Therefore, bleeding water from the high side hose, could cause the same effect as flushing the No. 2 test cock. In order to avoid premature activation of the relief valve in this manner, the Manual states that the tester should open the No. 3 test cock and bleed water from the low side of the field test kit while opening the No. 2 test cock very slowly.

Chapter 9.2.1.2 , 9.2.2.2, 9.2.3.2 step f:

Maintain the low side bleed needle valve in the open position and slowly open test cock No. 2 fully to pressurize the field test kit.

This, again, allows water to flow through the assembly keeping the differential pressure across the No. 1 check valve relatively high. The water continues to flow through the low side bleed needle valve until the No. 2 test cock is opened and the high side bleed needle valve is bled. After the No. 2 shutoff valve is closed, the low side bleed needle valve is only turned off after the high side is turned off. This ensures that water will continually be flowing through the No. 1 check valve when the high side of the field test kit is opened.

This is an example of how important it is to follow proper field test procedures, even though the details of the procedures—on the surface—may not seem to have an impact on the final outcome of the field test. In this case, even the order in which the test cocks are flushed is crucial to obtaining proper field data. ■

Testing the Double Check

When field testing the double check valve assembly, one obtains a reading on the first check valve and then takes a reading on the second check valve. In most cases, the tester may continue on to test the second check valve after testing the first check valve, even if the first check valve holds at a value below the minimum acceptable value of 1.0 psi. The exception to this is when the reading on the number one check valve is less than 1.0 psi AND the No. 1 shutoff valve leaks. Under these conditions, repairs must be made before continuing on to test the No. 2 check valve.



Chapter 9.3.3.2 of the *Manual of Cross-Connection Control, Tenth Edition* at Test T2 states:

After adjusting the bleed-off valve so that there is a slight drip at the No. 3 test cock, record the reading as the differential pressure drop across the No. 1 check valve. This reading should be 1.0 psid or greater. Return to Test No. 1, step h. if the reading is less than 1.0 psid, the No. 1 check valve must be repaired and retested before proceeding to Test No. 2.

What many testers do not understand is why the test must be stopped at this point to repair the check valve, even though at other times the tester may go on and test the

second check valve. One needs to look at the entire test in order to understand the reasoning.

After the first check valve has been tested, the high-pressure hose of the field test kit is moved to the No. 3 test cock and the sight tube (if needed) is moved to the No. 4 test cock. The No. 1 shutoff valve is reopened to repressurize the assembly. The sight tube is filled and the air is bled from the field test kit. Then the No. 1 shutoff valve is closed once again. With the gage at the same level as the water in the sight tube, the No. 4 test cock is opened.

At this point one of three scenarios occur. The water in the sight tube will remain steady, recede or overflow from the sight tube. Let us take a look at the third scenario, when the water in the sight tube overflows.

Chapter 9.3.3.5 of the Tenth Edition at T6 states:

If at Test No. 2 step d water continues to flow from the No. 4 test cock, one of the shutoff valves is leaking. Observe the reading on the field test kit, but do not record it at this time. Slowly open the bleed-off valve so there is a drip from the No. 4 test cock.

If it is not possible to adjust the bleed-off valve so there is no more than a drip from the No. 4 test cock, close bleed-off valve. Proceed to step T9.

Skipping to T9 we find:

If it is not possible to adjust the bleed-off valve so that the water flowing from the No. 4 test cock is no more than a drip, and if check valve No. 1 was holding less than 1.0 psid in Test No. 1, the No. 1 check valve must be repaired before testing the No. 2 check valve. Then return to Test No. 1, step a. If No. 1 check valve held 1.0 psid or more, proceed to step T10.

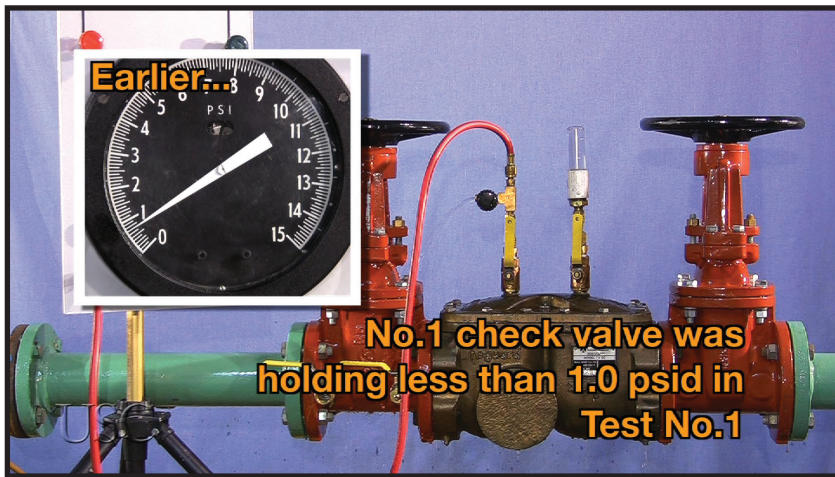

Next at step T10:

If check valve No. 1. was holding 1.0 psi or more in Test No. 1, close the bleed-off valve and close No. 4 test cock. Open the No. 2 test cock, then open the No. 4 test cock. Record the reading on the field test kit as the differential pressure across the No. 2 check valve. Also record No. 1 shutoff valve as leaking, and No. 2 shutoff valve as leaking with backpressure. Proceed to step No. 2 step e.

The important point to note is that the tester is not able to complete the test under the above circumstances if the first check held below 1 psi and there was a leaking No. 1 shutoff valve. To understand the reasoning behind this requirement, let's look at what is being done in step T10.

Water is flowing from the sight tube at the No. 4 test cock. After observing the reading, opening the bleed-off valve arrangement does not compensate for an upstream leak. Then, the bleed-off valve arrangement is closed and the No. 2 test cock opened. This is done in an attempt to get an accurate reading on the No. 2 check valve, even though water is flowing from the sight tube. If the water was flowing from an upstream shutoff valve leak, one should have been able to compensate for it, during the test of the No. 1 check valve. So, water must be coming from the downstream shutoff valve

with backpressure. However, to make sure that no water is flowing through the second check valve while we take a reading we open the No. 2 test cock fully. This bypasses any water from a leaking No. 1 shutoff valve to atmosphere at the No. 2 test cock. By doing this, leakage from both shutoff valves will be diverted so that check valve No. 2 may be tested. From Test No. 1 we know the Number one check valve holds at least 1 psi, the No. 1 check valve must be closed, since just upstream of the check valve is open to atmospheric pressure. With the No. 4 test cock, just downstream of the second check valve also open to atmosphere, the reading on the field test kit (while held at the level of the water in the sight tube) gives us the differential pressure across the No. 2 check valve.

If, in the above scenario, the No. 1 check valve was not holding, the water trapped between the two-check valves may leak backwards and out through the open No. 2 test cock. Once this pressure leaks away, the remaining reading will falsely indicate the condition of the No. 2 check.

From a pure technical sense, the 2nd check may be evaluated accurately providing the 1st check holds any value above 0.0, even a failing value of 0.1 to 0.9 psid. But in that case, the absolute accuracy of a tester's field test kit at the low end of the scale would be critical. So that the accuracy of a field test kit near 0.0 would not impact the field test procedure, the Manual Review Committee decided to require that the cut off point must be 1.0 or greater. This would provide a reasonable safety factor so that the tester would accurately assess the condition of both check valves, even if both shutoff valves leak.

Hopefully, this explanation helps explain why it is necessary to stop the test and repair the No. 1 check valve when the No. 1 check valve reading is less than one and there is a leaking No. 1 shutoff valve. ■

Location of **Test Cock No. 4** on

Detector Assemblies

The location of the test cocks on the Double Check Detector Assemblies (DCDA or DCDA-II) or Reduced Pressure Principle Detector Assemblies (RPDA or RPDA-II) may not seem to be an issue, but the Standards for these products require that the test cocks be in specific locations.

The Standards contained in Chapter 10 of the Foundation's *Manual of Cross-Connection Control, Tenth Edition* contain all the general design and material requirements, as well as the specific testing protocols.

Chapter 10.1.1.2.9 describes the required locations and sizes of test cocks on each type of assembly. As an example, the test cock locations for the DC and RP are described as:

- a. On the upstream side of the No. 1 shutoff valve.
Exception: Not required on 1/4 inch (6 mm) or 3/8 inch (10 mm) reduced pressure principle backflow prevention assemblies.
- b. Between the No. 1 shutoff valve and the No. 1 check valve
- c. Between the check valves
- d. Between the No. 2 check valve and the No.2 shutoff valve.

Backflow prevention assembly testers are familiar with this information since they routinely use the test cocks during their periodic field tests

In the Tenth Edition (and Ninth Edition) Standards for the detector assemblies (i.e.,

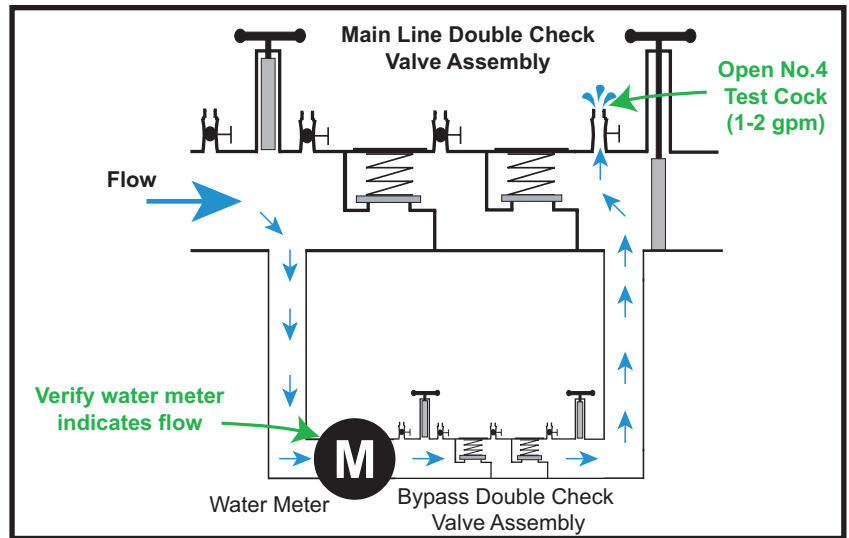

DCDA 10.1.2.6, DCDA-II 10.1.2.9, RPDA 10.1.2.7, RPDA-II 10.1.2.10) there is an additional requirement that the No. 4 test cock of the line-size assembly not be located on the bypass piping, and it can not be attached to the main-line body at the same location as the bypass piping.

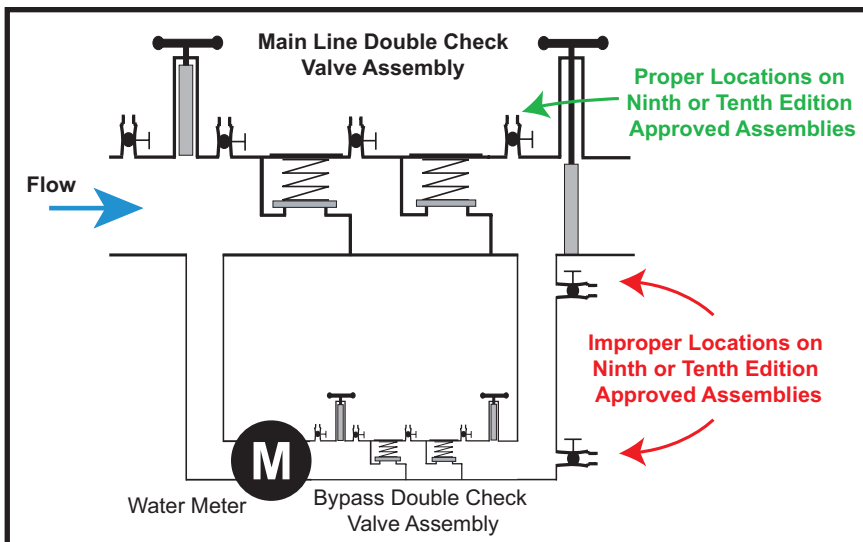

The primary reason for this requirement is to help field personnel to accurately verify the detection of flow through the bypass arrangement. The detector assemblies are designed to detect unauthorized use of water or any leaks in the system. All low flows up to two (2) gallons per minute must flow exclusively through the bypass arrangement and register accurately on the water meter. At greater flows water will flow through the mainline assembly as well as the bypass arrangement but the meter will not measure accurate flows.

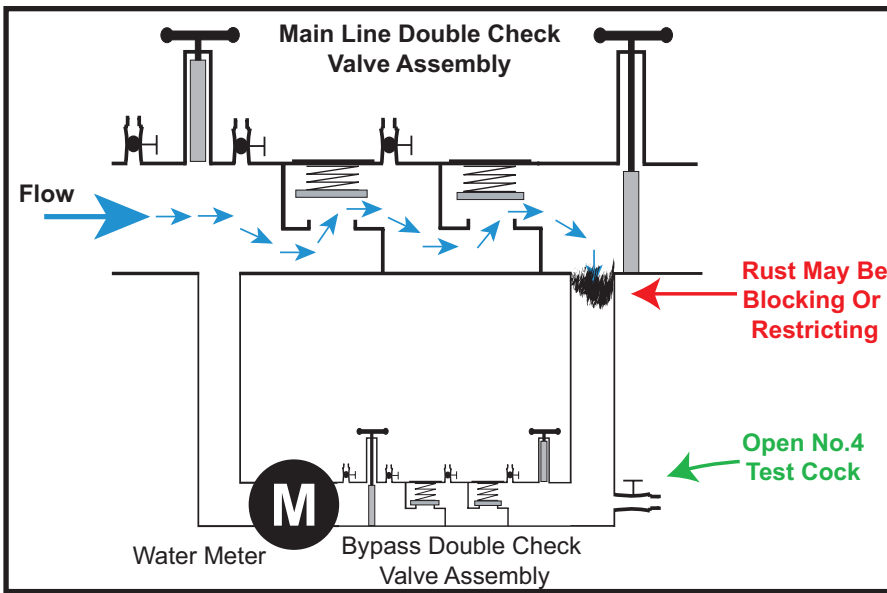

Figure A.5.1.2

If field personnel need to verify that the assembly is detecting low flows properly, there are steps included in the Tenth Edition Appendix A.5 Detector Assemblies: Operation of Bypass. These procedures detail how this field verification can be performed. If the No. 4 test cock is not located on the bypass piping, then the flow detection test can simply be performed by opening the No. 4 test cock to create a small flow (1-2 gpm) and verifying that the water meter indicates flow.

However, if the No. 4 test cock is located on the bypass piping (Note: permitted on assemblies approved per Eighth Edition or earlier), then a separate diagnostic step (Figure A.5.1.2) must be performed

to verify the operation of the bypass. If the bypass piping is clogged or restricted then the assembly may not detect unauthorized flow. Over the years it has been found that some field personnel did not recognize that the blockage of the bypass piping could provide a false indication on the water meter. Requiring the location of the No. 4 test cock on the body of the main-line assembly, together with the new verification tests in the Tenth Edition, provides better tools for field personnel to make accurate assessments of operation. ■



Test Cock No. 4 located on the bypass piping

hydraulic lock: continued

continued from page 4

check valve is still very difficult to remove, the tester should not force it. This could be caused by a damaged or deformed part. The tester should be very careful not to damage the check valve in the process of trying to remove it. ■

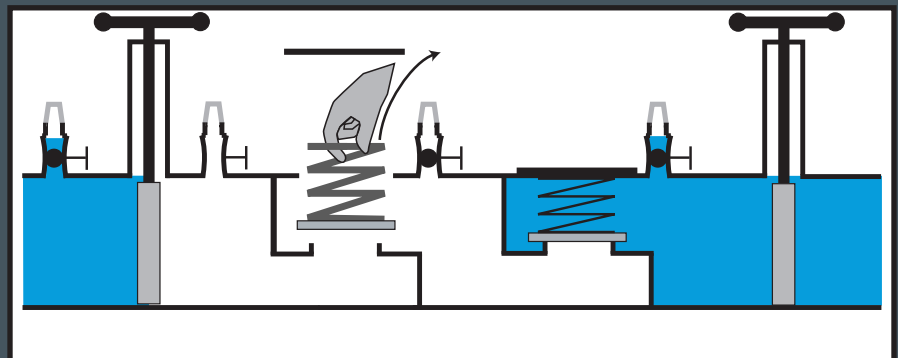

After opening test cock number two, the hydraulic lock is broken, and the tester is able to remove the internal components

Training Courses

Tester Course

Los Angeles, CA
9-13 July 2012

Los Angeles, CA
15-19 October 2012

Specialist Course

Los Angeles, CA
23-27 July 2012

Upcoming Events

Southern California Chapter ABPA
Backflow Industry Product Fair
Los Angeles, CA
26 June 2012

ABPA Western Regional
Backflow Conference
Las Vegas, NV
24-26 September 2012

CA-NV AWWA
Annual Fall Conference
San Diego, CA
8-11 October 2012

Social Media

follow us at twitter.com/uscfccchr

become a fan by clicking 'Like' on our
facebook page
facebook.com/uscfccchr



Contact Information

Phone: 866-545-6340

Fax: 213-740-8399

E-mail: fccchr@usc.edu

Website: fccchr.usc.edu

**Foundation for
Cross-Connection Control
and Hydraulic Research**

University of Southern California
Kaprielian Hall 200
3620 South Vermont Avenue
Los Angeles, California 90089-2531

First Class
US Postage PAID
University of
Southern California



USC University of
Southern California